

REV 更改号	DATE 日期	REVISION DETAILS 更改内容	APPD 审核并批准
A	19/08/2016	PRODUCTION ISSUE	
B	Jan.4,2019	Change 1.8 +/-0.05 to 1.35 +0.1/-0.1	Zhang

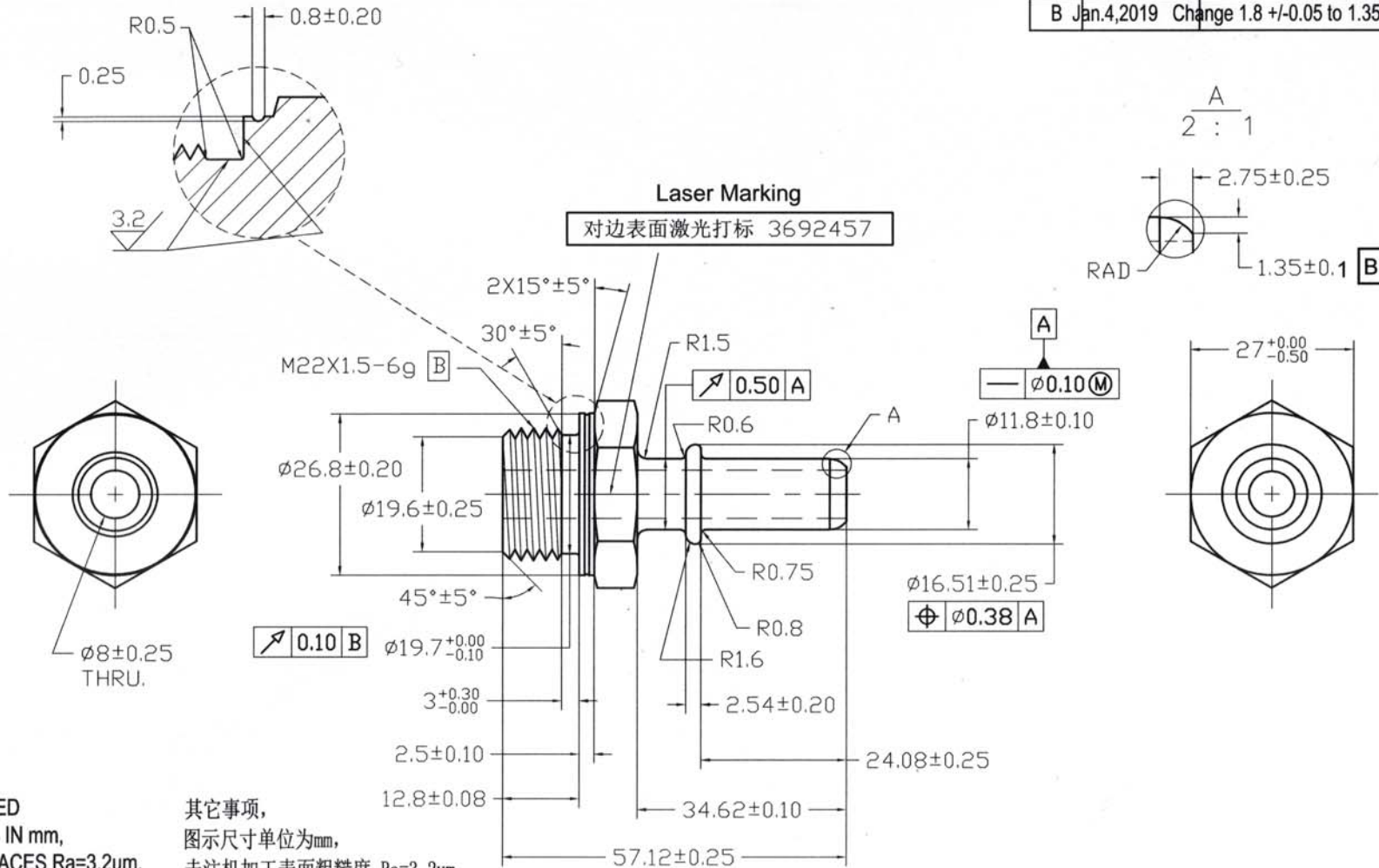

UNLESS SPECIFIED
ALL DIMENSIONS IN mm,
MACHINED SURFACES $Ra=3.2\mu m$,
ANGLE TOLERANCES $\pm 1^\circ$,
Other tolerance except angles,
in accordance with
GB/T1804-2000(ISO2768-1)-m
and GB/T1184-1996(ISO2768-2)-m

其它事项,
图示尺寸单位为mm,
未注机加工表面粗糙度 $Ra=3.2\mu m$,
未注角度公差 $\pm 1^\circ$,
其它未注公差(除角度外)均按:
GB/T1804-2000(ISO2768-1)-m 和
GB/T1184-1996(ISO2768-2)-m

PART No 零件名		41162-M22-12MM QC	
SCALE:	APPD: 批准	DRN: 制图	Panda 2016.08.19
NTS	DATE: 日期	CHK: 审核	Panda 2016.08.19

MATERIAL Chinese steel 45

FINISH

Remove all sharp edges,burrs,slivers and swarf, break all edges 0.127-0.254mm.
zinc plating with minimum 8microns thickness and trivalent chromate passivation and withstand 96 hrs to white / 144 hrs to red rust in salt spray test.

去除所有毛刺, 铁屑等残留物, 锐边倒钝0.127-0.254mm.
镀三价铬锌, 银白色, 盐雾试验96小时无白锈, 144小时无红锈